

| REVISION RECORD | | | |
|-----------------|--|----------|--------------|
| LTR | DESCRIPTION | DATE | BY |
| E | ITEM 3 WAS 2910-C038-0A SB2500SW | 1-7-92 | 12548 CL |
| F | REDRAWN ON AUTOCAD, DELETED -1A THRU -3A ASSY'S. UPDATED DWG. AND BOM TO CURRENT PRODUCTION PRACTICE | 10/10/96 | 15091 C.H. |
| G | ITEM 7, SHOW NEW STYLE J-BOX | 4/24/97 | 15564 EMJ/SC |
| H | UPDATED POSITION OF RAMP SLOT, UPDATED LOCATION OF J BOX, | 5/11/98 | 16001 RN/GPL |
| J | ADD ITEM 18 MOUNTING STRAP ROTATE J-BOX 90° | 10/2/00 | 21089 JAT |

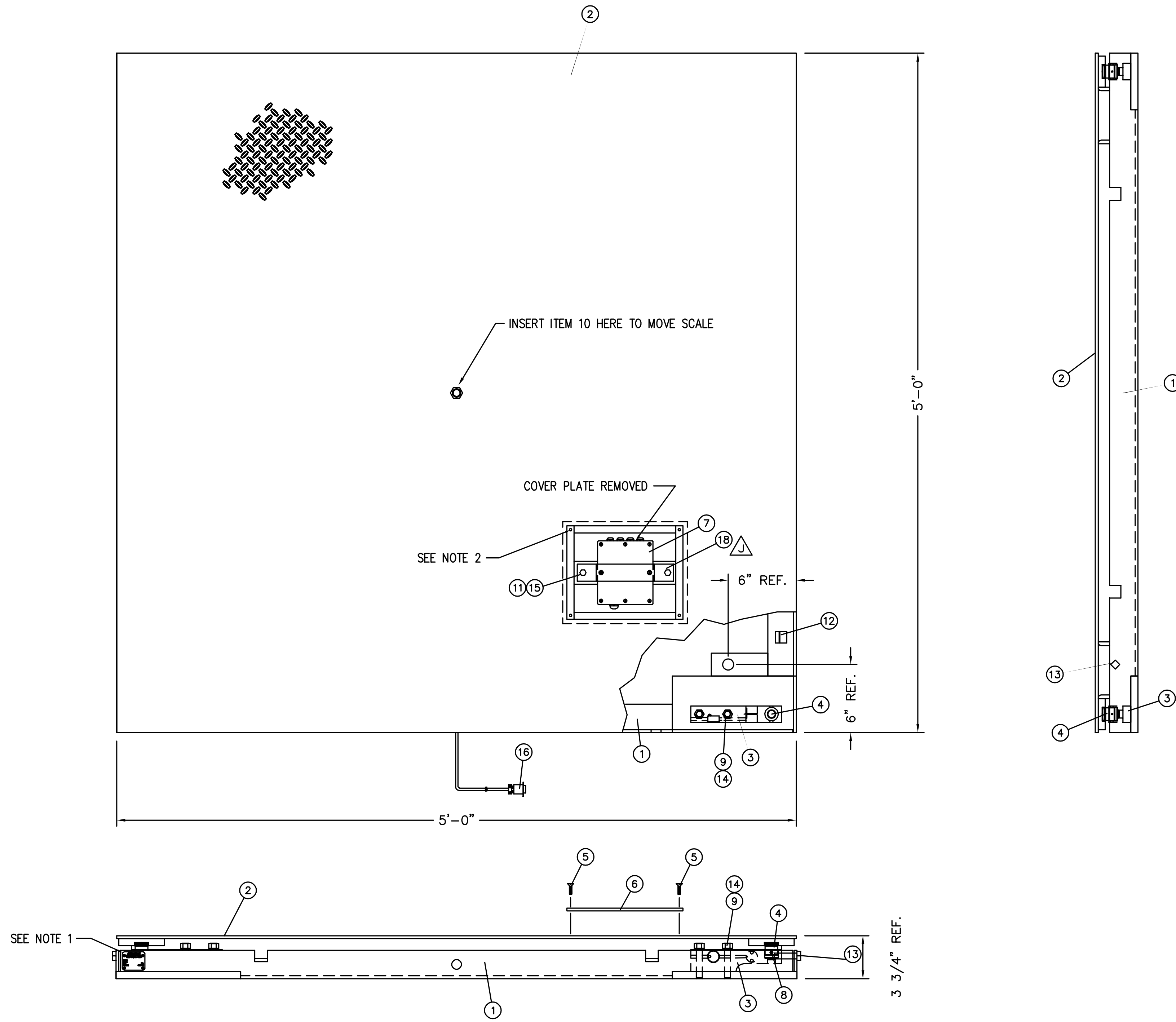

- NOTES:**
- REF. DRAWING 1905-B207-0A FOR LOCATION OF SERIAL TAG AND LOGO.
 - MATCH DRILL THESE HOLES THRU ITEM 6 AND THEN TAP 10-24 UNC 2B THE HOLES IN THE WEIGHBRIDGE. SECURE ITEM 6 WITH ITEMS 5.
 - SCALE MUST BE INSTALLED ON A SMOOTH AND LEVEL SURFACE.
 - REMOVE ITEM 6 FOR ACCESS TO JUNCTION BOX FOR CALIBRATION PURPOSES.
 - FOR PIT PLAN REF. DWG. 1902-C012.
 - ITEM 13 MUST NOT BE IN CONTACT WITH THE WEIGHBRIDGE WHILE SCALE IS IN OPERATION.
 - FOR ELECTRICAL INTERCONNECTION REF. DWG. 3502-B208-02.
 - REMOVE ITEM 13 WHEN SCALE IS TO BE INSTALLED IN A PIT.
 - RAMP SLOPE IS APPROX. 6.5°.

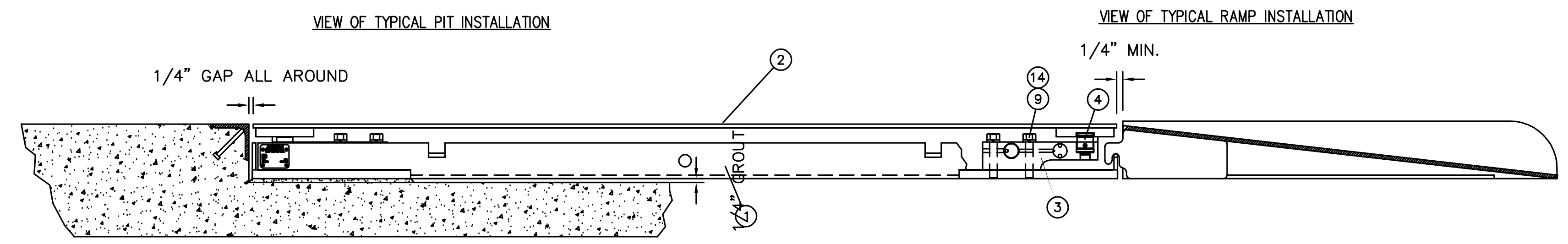

| QTY. | QTY. | QTY. | ITEM | PART/DWG. NUMBER | DESCRIPTION | MATERIAL OR SOURCE | WT. EACH |
|------|------|------|------|------------------|-------------------|-----------------------------|----------|
| | | 1 | 18 | 3502-B462-08 | MOUNTING STRAP | | 0.3 |
| | | 1 | 17 | 1905-B207-0A | I.D. MARKING | | - |
| | | 1 | 16 | 3502-B396-0A | L.C. CABLE | 9 PIN "D" CONN. | 1.0 |
| | | 2 | 15 | 6024-0039 | LOCK WASHER | 1/4" | 0.01 |
| | | 8 | 14 | 6007-1004 | HEX HEAD BOLT | 1/2-20 UNF x 2 1/2" GRADE 5 | 0.18 |
| | | 2 | 13 | 6007-3000 | SQ. HEAD SCREW | 1/2-13 UNC x 2" DOG POINT | 0.16 |
| | | 12 | 12 | 6610-5007 | CABLE CLIP | | 0.01 |
| | | 2 | 11 | 6007-0007 | HEX HEAD BOLT | 1/4-20 x 3/8" | 0.1 |
| | | 1 | 10 | 418R1047 | EYE BOLT | 5/8" | .8 |
| | | 8 | 9 | 6024-0048 | LOCK WASHER | 1/2" | 0.07 |
| | | 8 | 8 | 6020-0012 | SPRING PIN | 1/8" DIA. x 1/2" | .01 |
| | | 1 | 7 | 3502-C208-0A | JUNCTION BOX | | 2.5 |
| | | 1 | 6 | 1905-B103-08 | COVER PLATE | | 7.5 |
| | | 4 | 5 | 6021-1201 | FLAT HEAD SCW. | 10-24 x 3/4" PHILLIPS DR. | 0.15 |
| | | 4 | 4 | 3500-B067-08 | ROCKER WASHER | | 0.4 |
| | | 4 | 3 | SB-5000S | LOAD CELL | 2910-C019-0A | 9.0 |
| | | 1 | 2 | 1905-C031-5A | WEIGHBRIDGE ASSY. | | 477.691 |
| | | 1 | 1 | 1905-C031-5A | BASE ASSY. | | 132.925 |

UNLESS OTHERWISE SPECIFIED TOLERANCE ON DIMENSIONS ARE:
 ANGLES ± 1/2°
 INTEGERS/FRACTIONS ± 1/16 IN.
 DECIMALS (X) ± .03 IN.
 DECIMALS (XX) ± .01 IN.
 DECIMALS (XXX) ± .005 IN.
 NOTE: WHOLE NUMBERS MUST BE WRITTEN XX.000 TO INVOKE DECIMAL TOLERANCES.

THIS DRAWING IS THE PROPERTY OF THE CARDINAL SCALE MFG. CO. AND SHALL NOT BE USED NOR REPRODUCED EITHER WHOLLY OR IN PART EXCEPT WITH WRITTEN AUTHORIZATION. ALL RIGHTS OF DESIGN OR INVENTION ARE RESERVED.

Cardinal
 Cardinal Scale Manufacturing Co.
 WENONA, ILL. U.S.A. 61890

CARDINAL DETECTO FULLER WEIGHING SYSTEMS

TITLE: FINAL ASSY: FH-1055-II

SCALE: 1/6 DO NOT SCALE DRAWING NEXT ASSEMBLY

DR. C. LUSH DATE 6/5/86

CH. DATE

MODEL: FH-1055-II SHEET 1 OF 1 DWG. NO. 1906-D004-0A REV. J