

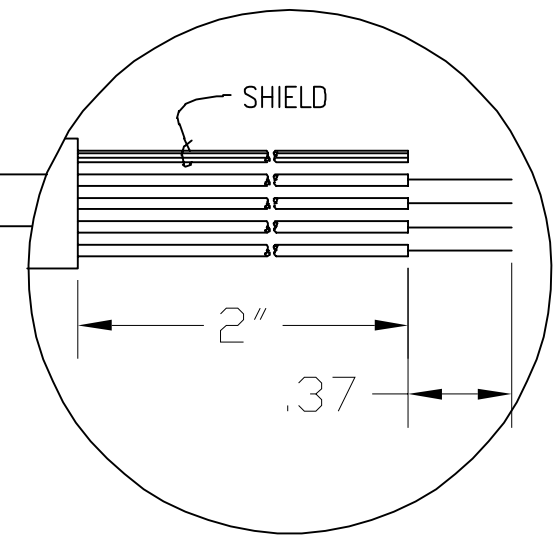

REVISION RECORD			
LTR	DESCRIPTION	DATE	BY
A	RELEASED FOR PRODUCTION	6/12/07	23991 GPL

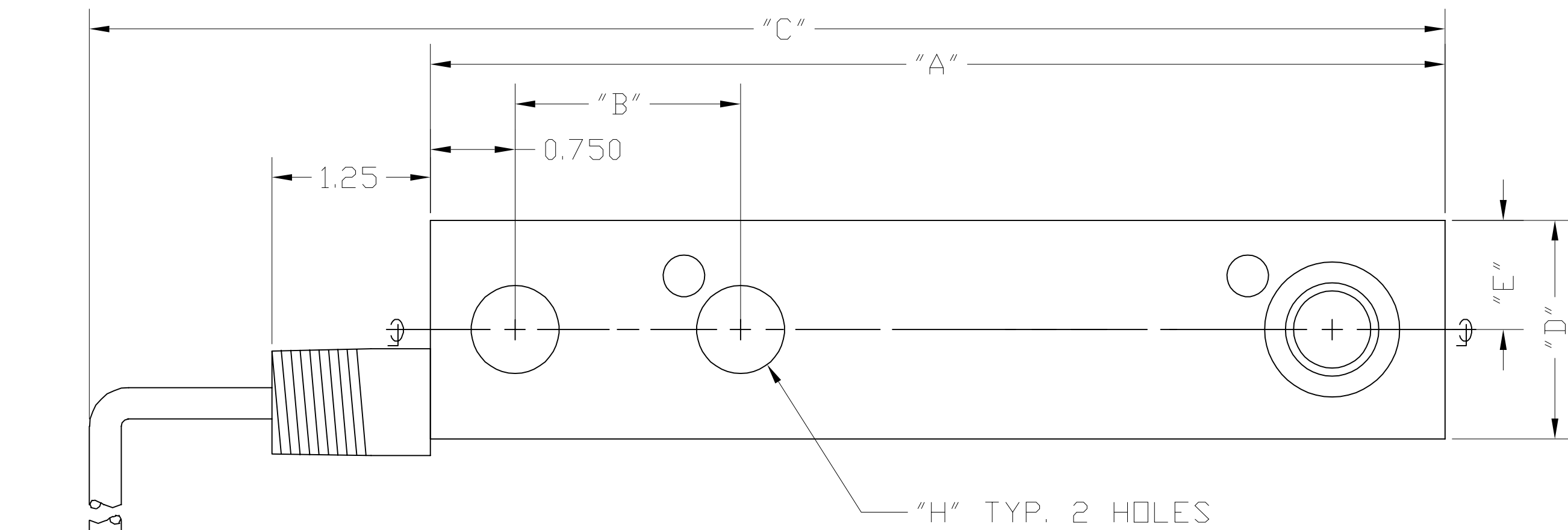
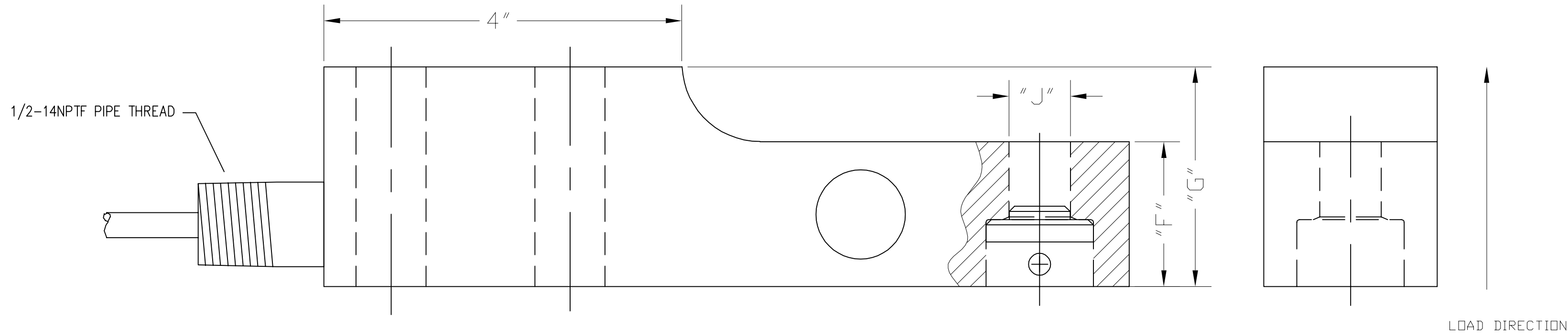

MODEL NO.	CAPACITY	PART NO.	"A"	"B"	"C"	"D"	"E"	"F"	"G"	"H"	"J"
SB-2500S	2500 lb	2910-C018	8.000	2.500	10.5	1.450	0.725	1.25	1.938	0.532 DIA THRU	3/4-16 UNC-2A
SB-5000S	5000 lb	2910-C019	8.000	2.500	10.5	1.450	0.725	1.44	1.938	0.532 DIA THRU	3/4-16 UNC-2A
SB-10000S	10000 lb	2910-C021-0A	9.000	2.000	11.5	1.940	0.970	1.62	2.460	0.782 DIA THRU	0.687 DIA
SB-20000S	20000 lb	2910-C023-0A	9.000	2.000	11.5	1.940	0.970	2.00	2.460	0.782 DIA THRU	0.687 DIA

QTY.	QTY.	QTY.	ITEM	PART/DWG. NUMBER	DESCRIPTION	MATERIAL OR SOURCE	WT. EACH
			ASSY				
			WT.	PARTS/MATERIAL LIST			
UNLESS OTHERWISE SPECIFIED TOLERANCE ON DIMENSIONS ARE: ANGLES ± 1/2° INTEGERS/FRACTIONS ± 1/16 IN. DECIMALS (.X) ± .03 IN. DECIMALS (.XX) ± .01 IN. DECIMALS (.XXX) ± .005 IN. NOTE: WHOLE NUMBERS MUST BE WRITTEN XX.000 TO INVOKE DECIMAL TOLERANCES.				 CARDINAL DETECTO FULLER WEIGHING SYSTEMS TITLE SB-XXXXXS LOAD CELL OUTLINE DRAWING			
THIS DRAWING IS THE PROPERTY OF THE CARDINAL SCALE MFG. CO. AND SHALL NOT BE USED NOR REPRODUCED EITHER WHOLLY OR IN PART EXCEPT WITH WRITTEN AUTHORIZATION. ALL RIGHTS OF DESIGN OR INVENTION ARE RESERVED.		SCALE	NTS	DO NOT SCALE DRAWING	NEXT ASSEMBLY	CUSTOMER DRAWING (ENGLISH)	
DR.	GPL	DATE	6/12/07				
CH.		DATE					
MODEL	SB-XXXXXS	SHEET	1 OF 2	DWG. NO.	2910-C085-0A	REV.	A