

Cardinal LOAD CELLS

SERIES SB - BEAM TYPE - FOR MEDIUM TO HEAVY WEIGHING

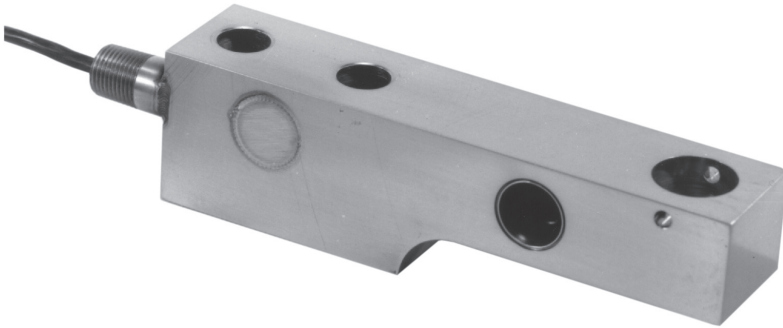

- Capacities from 1130 kg to 9000 kg
- Highly resistant to eccentric loading
- Waterproof construction
- Stainless steel models for corrosion resistance
- Low profile design
- 6 m integral shielded cable

Beam cells with capacities from 1130 kg to 9000 kg promote a variety of applications, such as low profile platform scales, tank and/or hopper weighing, and other process control systems. The design of these cells makes them highly resistant to eccentric loads. Construction of high grade stainless steel in these cells offers strength, and the ultimate in protection when caustic or corrosive environments are encountered. Provided with the cell are mounting holes for securing cell, and a 6 m integral multiconductor shielded cable secured by a compression strain relief seal.

These cells are welded closed, providing superior waterproofing, while remaining flexible over the life of the load cell. This protects the load cell strain gages, and over a broad temperature range, has no effect on load cell precision accuracy.

SPECIFICATIONS

Mechanical Data

Rated Capacity, (R.C.) E_{max} . 1130, 2260, 4500 & 9000 kg
 Minimum Dead Load 0 kg
 Safe Load Limit..... 150% R.C.
 Ultimate Load 300% R.C.
 Deflection at R.C..... .38 to 0.97 mm
 Spring Element Material 17-4 PH
 Net Weight 2.3 to 4.7 kg

Environmental Data

Temperature Compensation
 Range -10½ to 40½C
 Operating Temperature Range .. -29½ to 93½C
 Construction & Protection
 Code CP-67 HU, IP68
 Barometric Pressure Effect
 on Zero Load Output <1 v (min)/1kPa

Electrical Data

Rated Output 2mV/V
 Excitation Voltage,
 Recommended 10 VDC
 Excitation Voltage,
 Maximum 15 VDC
 Cable Length 6 m
 Terminal Resistance
 Excitation 386 ± 12 ohms
 Signal..... 350 ± 5 ohms
 Zero Load Output ± 1% R.C.
 Insulation Resistance >5000 megohms at
 50 VDC

Color Code

+ Excitation Green
 - Excitation Black
 - Signal White
 + Signal Red

Certificate Data

Issuing Body NTEP OIML
 Certificate Number 87-059A1 R60/1991-DK-97.02
 Accuracy Class..... III/IIIL C3
 Maximum Number of LoadCell Intervals, n_{max} 5000/10000 3000
 Single/Multiple S/M
 Humidity Symbol..... CH
 Minimum Load Cell Verification Interval V_{min} III - 0.16, 0.32, 0.64 & 1.27 kg 0.086, 0.17, 0.35 & 0.70 kg
 IIIL - 0.1, 0.2, 0.4 & 0.8 kg

Cardinal BEAM TYPE LOAD CELLS

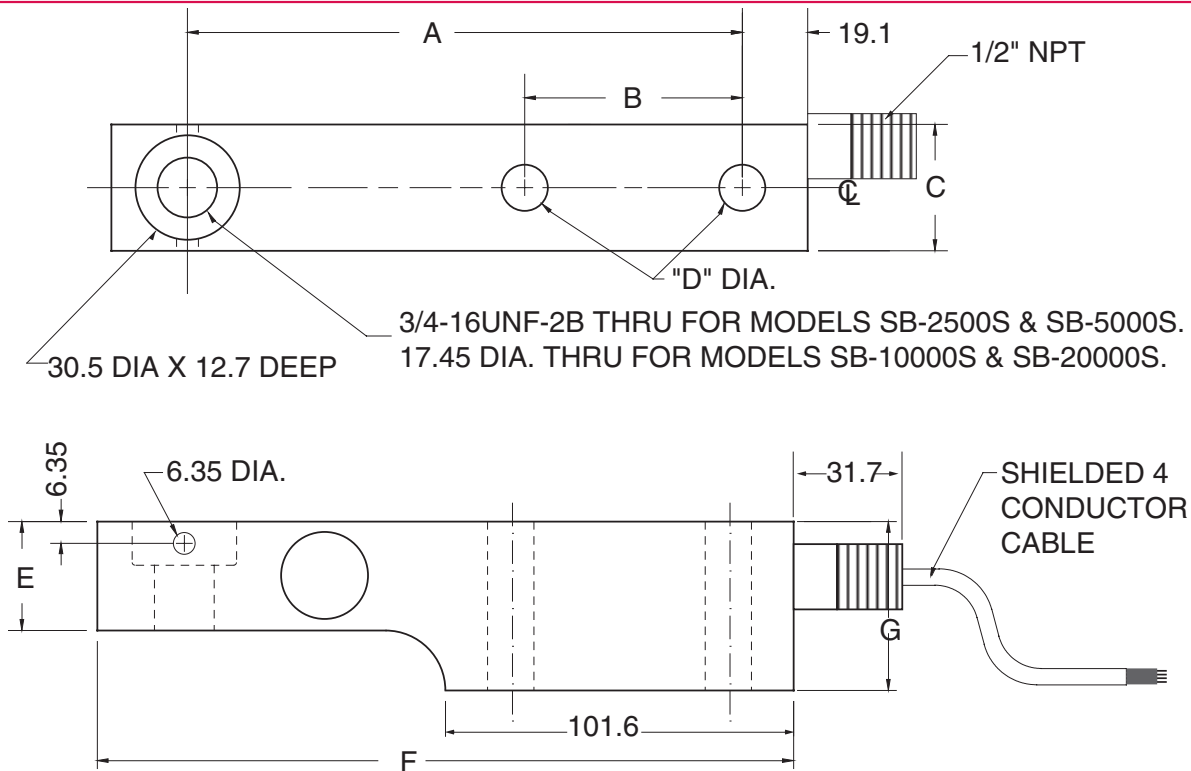

DIMENSIONAL INFORMATION

MODEL	CAPACITY	"A"	"B"	"C"	"D"	"E"	"F"	"G"
SB-2500S	1130 kg	161.9	63.5	36.8	13.51 dia thru	31.7	203.2	49.2
SB-5000S	2260 kg	161.9	63.5	36.8	13.51 dia thru	36.8	203.2	49.2
SB-10000S	4500 kg	184.2	50.8	49.3	19.86 dia thru	41.1	228.6	62.5
SB-20000S	9000 kg	184.2	50.8	49.3	19.86 dia thru	50.8	228.6	62.5

All dimensions are in mm unless otherwise noted.



The SB Series Load Cells meet all requirements of OIML R60 and has been issued OIML certificate no. R60/1991-DK-97.02.



The SB Series Load Cells meet all requirements of Handbook 44, issued by the National Institute of Standards and Technology and have been issued the NTEP Certificate of Conformance No. 87-059 A1.



Cardinal Scale reserves the right to improve, enhance and modify features and specifications without prior notice.

ELECTRICAL INFORMATION

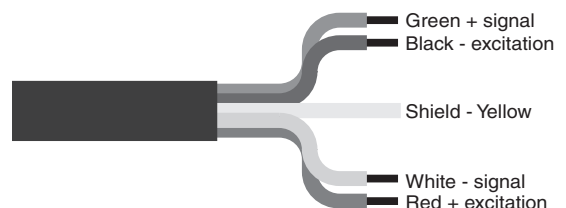

203 East Daugherty
P.O. Box 151
Webb City, Mo 64870

Phone: 417•673•4631
Fax: 417•673•5001
www.cardinalscales.com